

a design portfolio

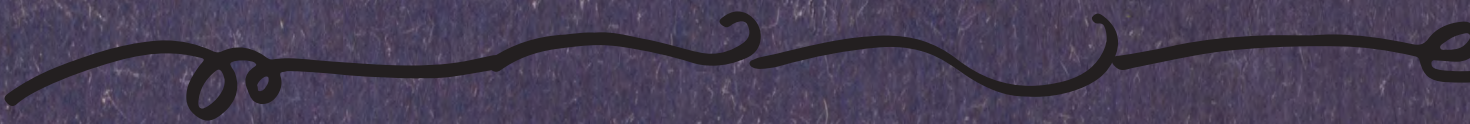

www.purniadesigns.com

Purnia Farrukh



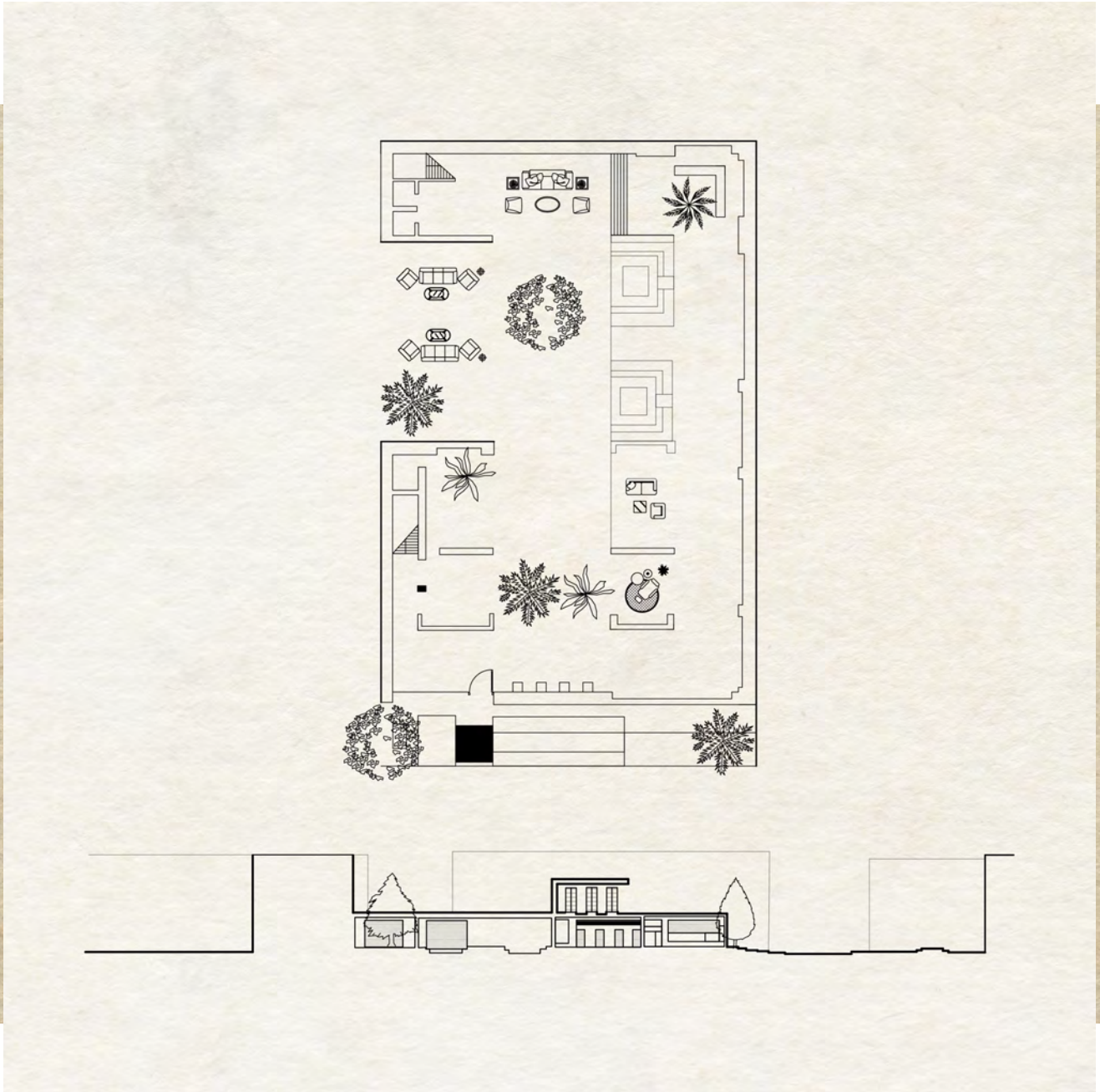

multi-cultural. graphic design. architectural design. environmental design.



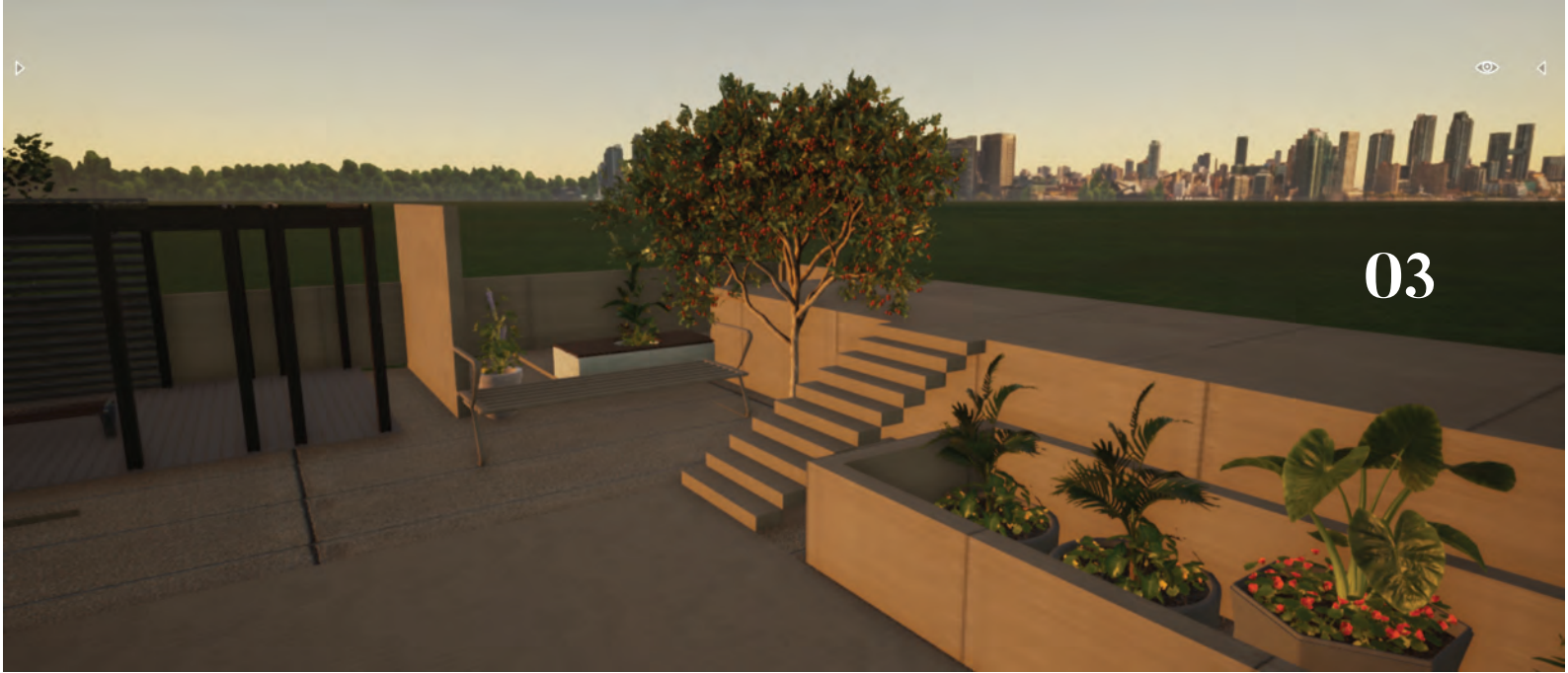

a few works

Design is also intuition, that form of subconscious thought that leads to a deeper sense of knowing, often in the apparent absence of rational confirmation. Intuition is akin to an elongated insight that tells us that we are on to something. It is the hunch that often underlies efforts to perform rational analysis.

The nature of this process, which is often modeled as a linear sequence of events is in reality a highly complex, multifaceted set of thought-filled activities. While design is linear in the sense that it is sequenced in time as one moves from initial concept to a completed product, it is also non linear. Design thought often jumps in discontinuous steps from one aspect of a problem to another as it searches for a solution. It is also multi-veiled in the sense that overall systems, subsystems, and even minute details often need to be considered simultaneously.





a few sketches

*a wise man once said don't
attempt to render a tree*

i get it now.

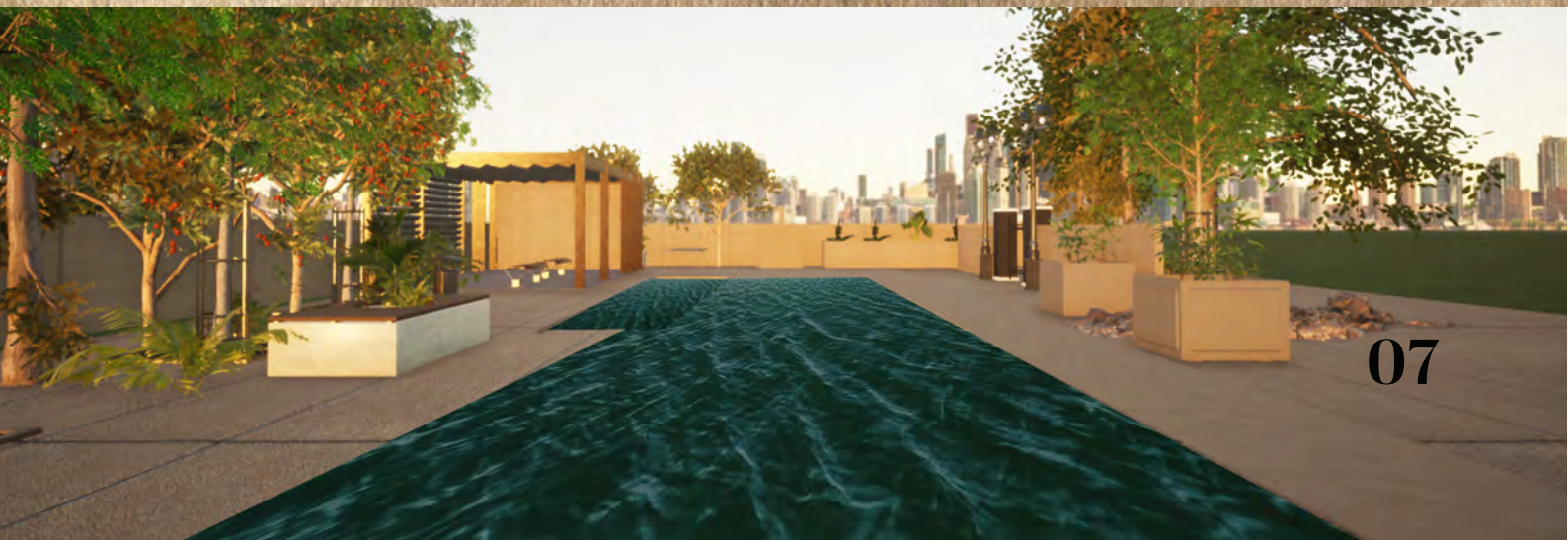
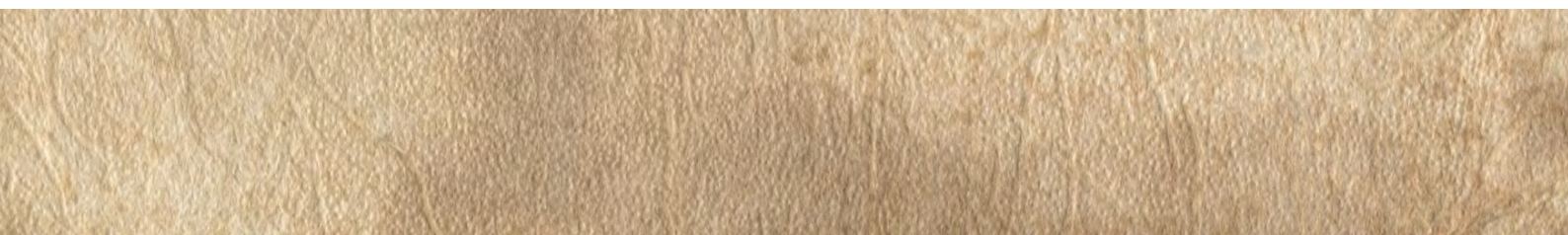



a few moods

just a few

Any entity can be designed or created with intent and purpose. The total thought process encompassing the creation of that entity- the process that gives its form, be it physical, temporal, conceptual or relational- is design.



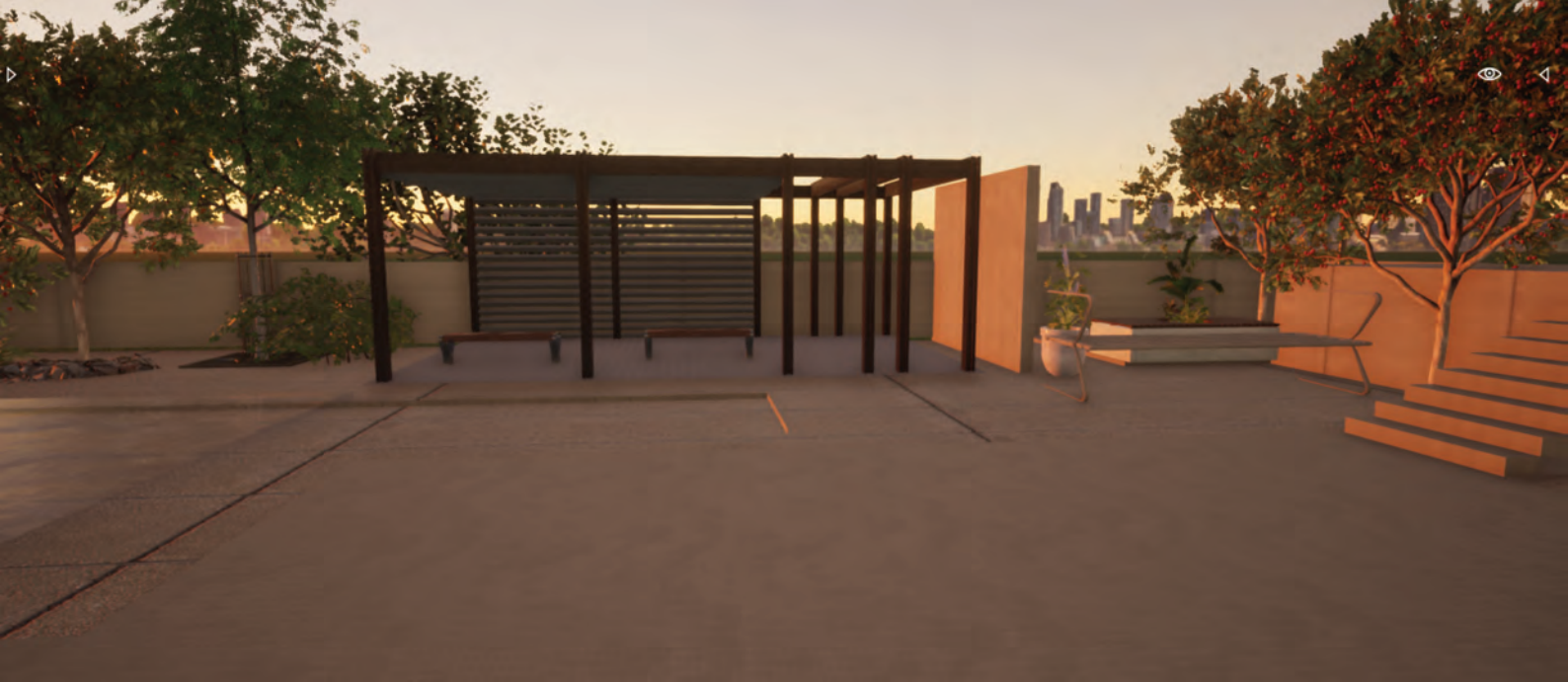

SECTIONS & RENDERS
twinmotion and rhino

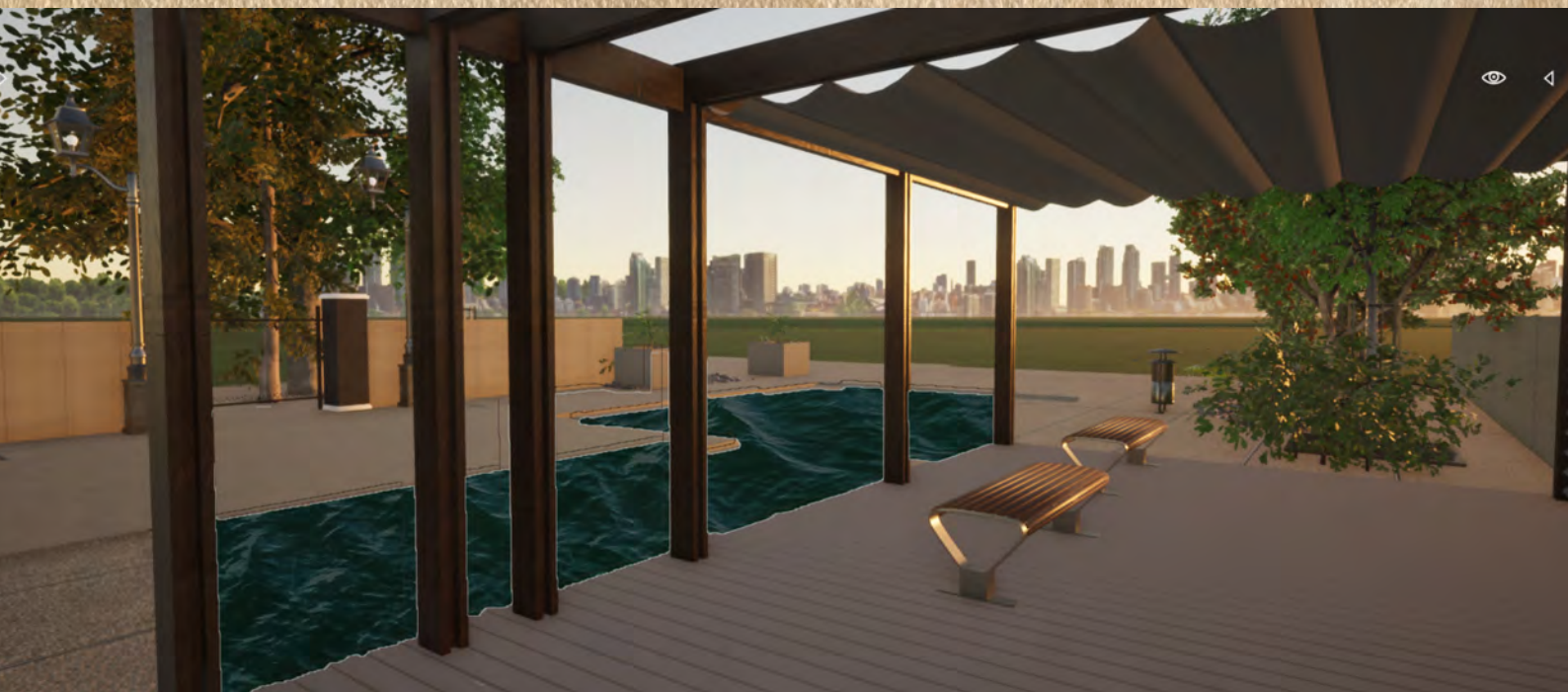
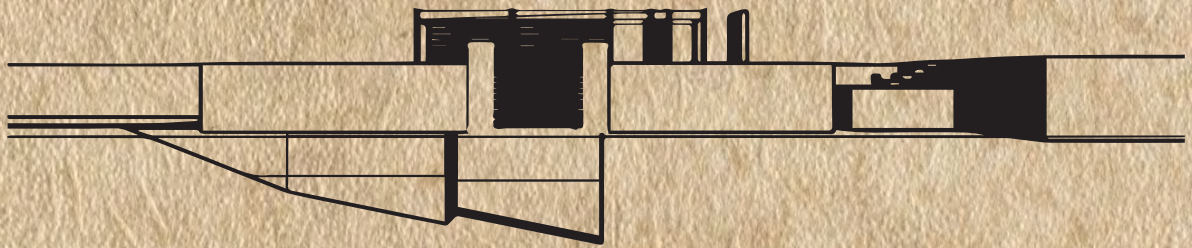

MULLIN WINE BAR

an imagined landscape



MULLIN WINE BAR

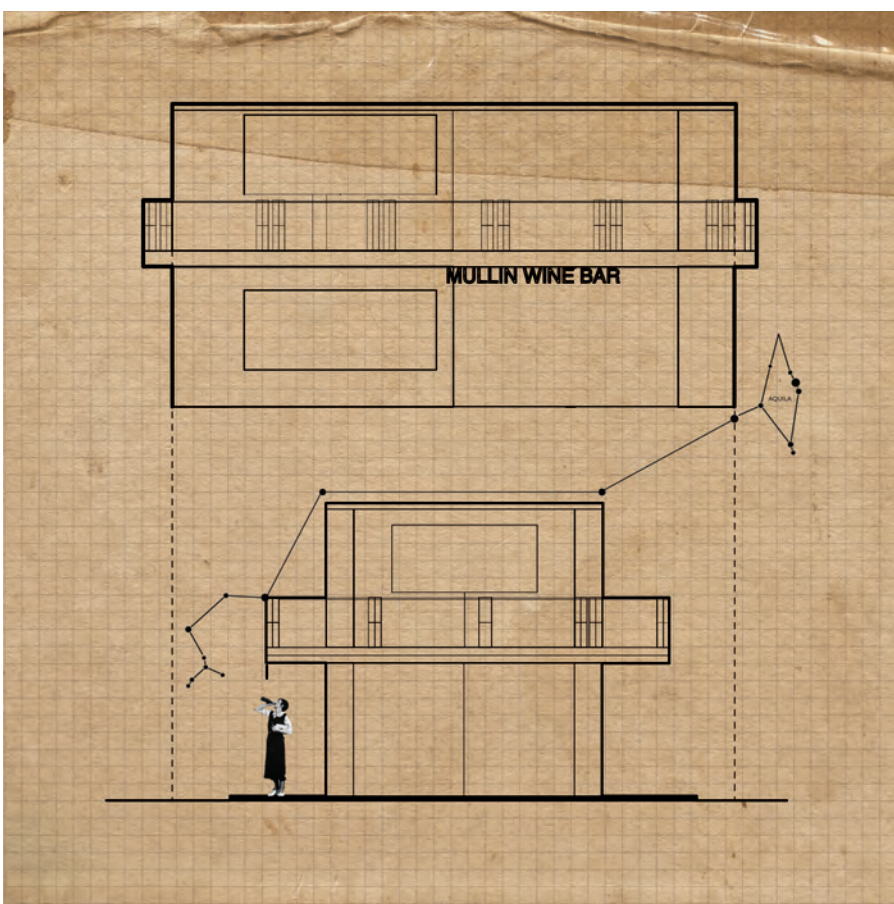

010

MULLIN
WINE
BAR



Illustrative
Collage

design

Design is also intuition, that form of subconscious thought that leads to a deeper sense of knowing, often in the apparent absence of rational confirmation. Intuition is akin to an elongated insight that tells us that we are on to something. It is the hunch that often underlies efforts to perform rational analysis.

The nature of this process, which is often modeled as a linear sequence of events is in reality a highly complex, multifaceted set of thought-filled activities. While design is linear in the sense that it is sequenced in time as one moves from initial concept to a completed product, it is also non linear. Design thought often jumps in discontinuous steps from one aspect of a problem to another as it searches for a solution. It is also multi-veiled in the sense that overall systems, subsystems, and even minute details often need to be considered simultaneously.

This comprehensive thought-filled process is directed toward and culminates in creation. That is, it leads to the tangible realization of an entity (the thing being designed) in time and space. An entity can be an object that occupies space, an event that occurs in time, a concept (such as the theory of relativity) or a relationship (such as treaty between nations). Most entities are complex in that they contain two or more of these entity types.



illustrative collages are good

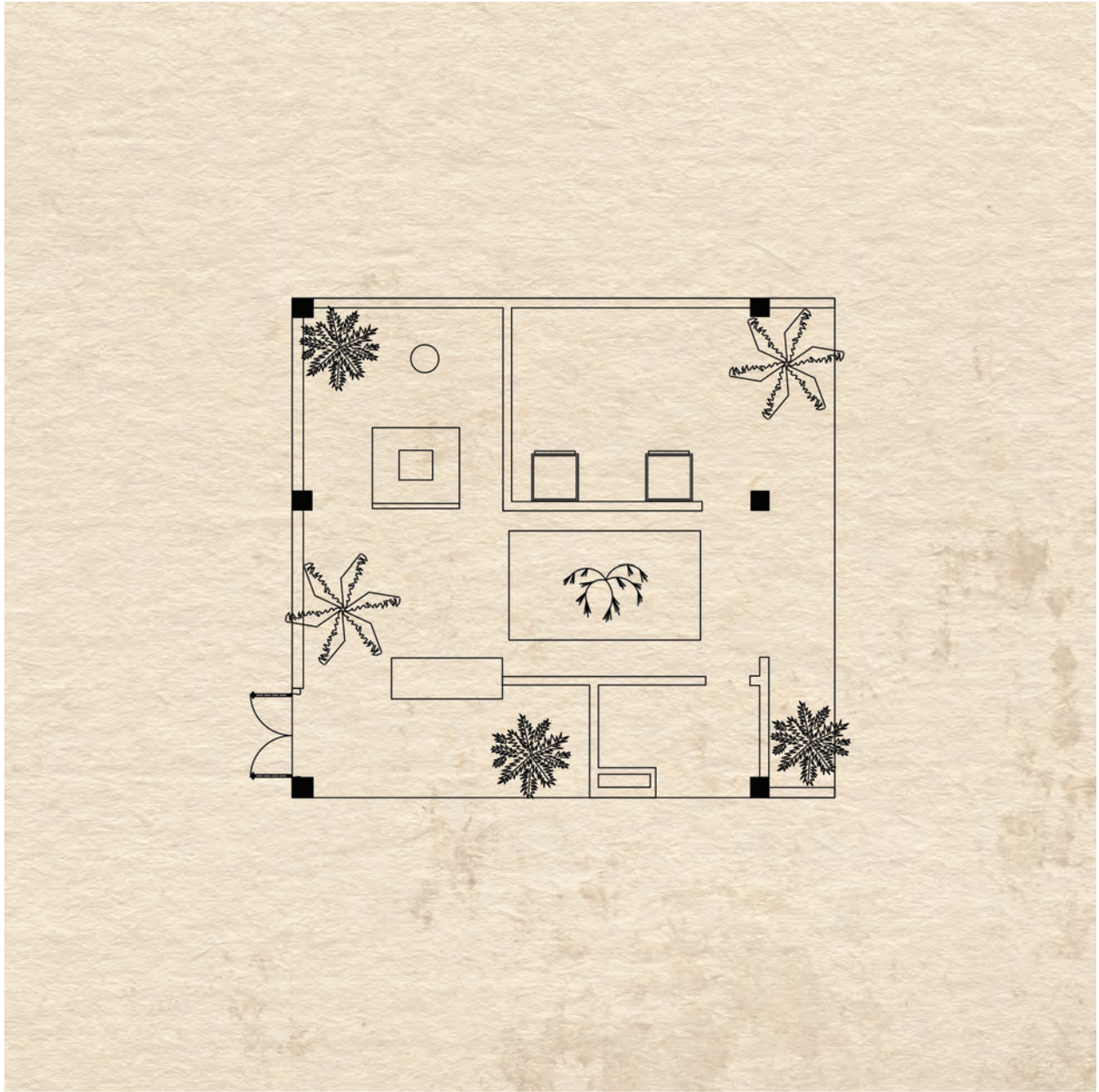

Vintage Drafting w/photoshop



an imagined landscape that's
almost believable



Grids and what not

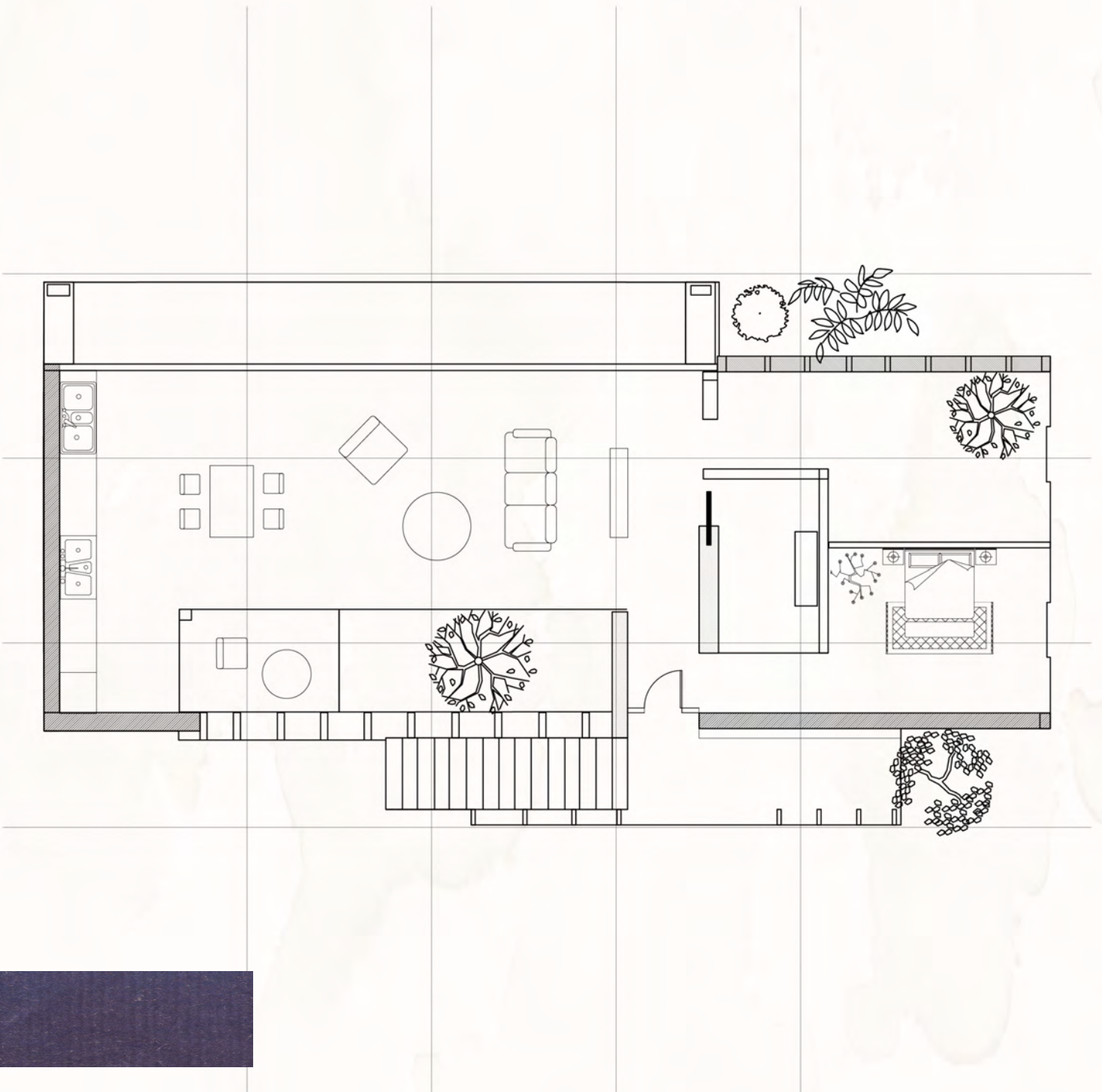

*unpopular opinion:
design is more important than technology*

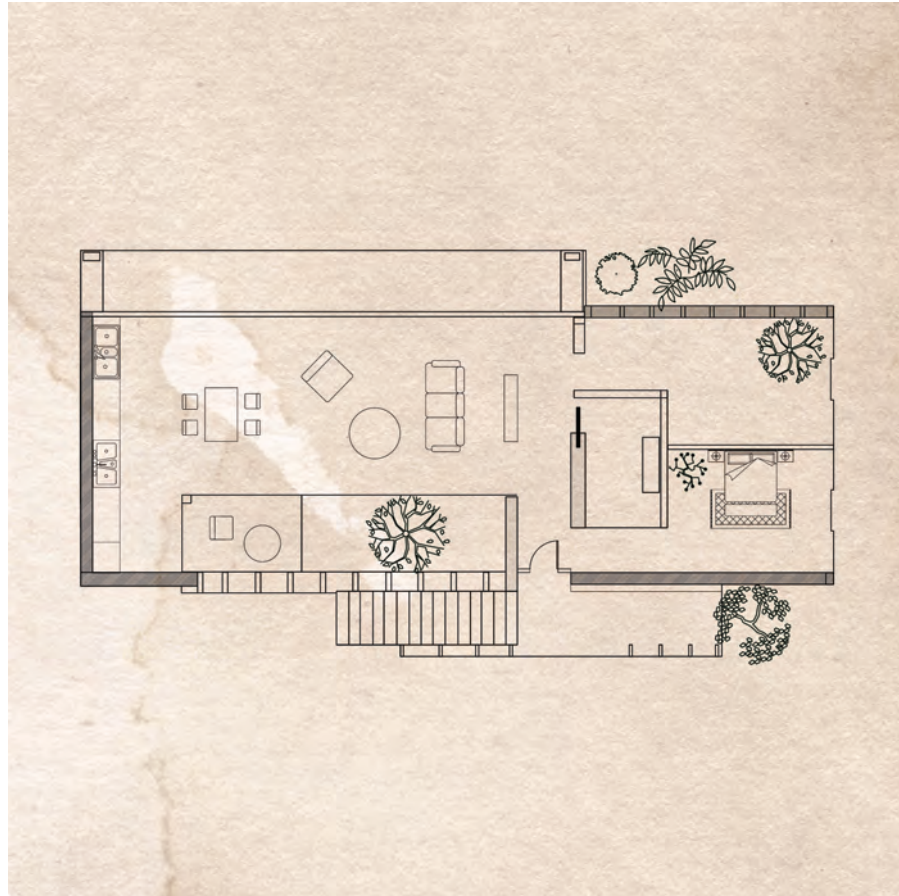

Well, here's the thing: When it comes to technology, "innovation" doesn't mean what you think it means.

It didn't invent the touchscreen, or mobile e-mail, or that cool portrait/landscape switching that we now take for granted.

Apple didn't invent the MP3 player.

It just invented a better way to call and pay for them that took advantage of the smartphone platform.

Uber didn't invent cabs

I believe that design has the potential to transform how organizations develop products, services, processes, strategies, and cultures.

*Make a friend who has CAD BLOCKS.
No need to go on the Dark Web*

0.4

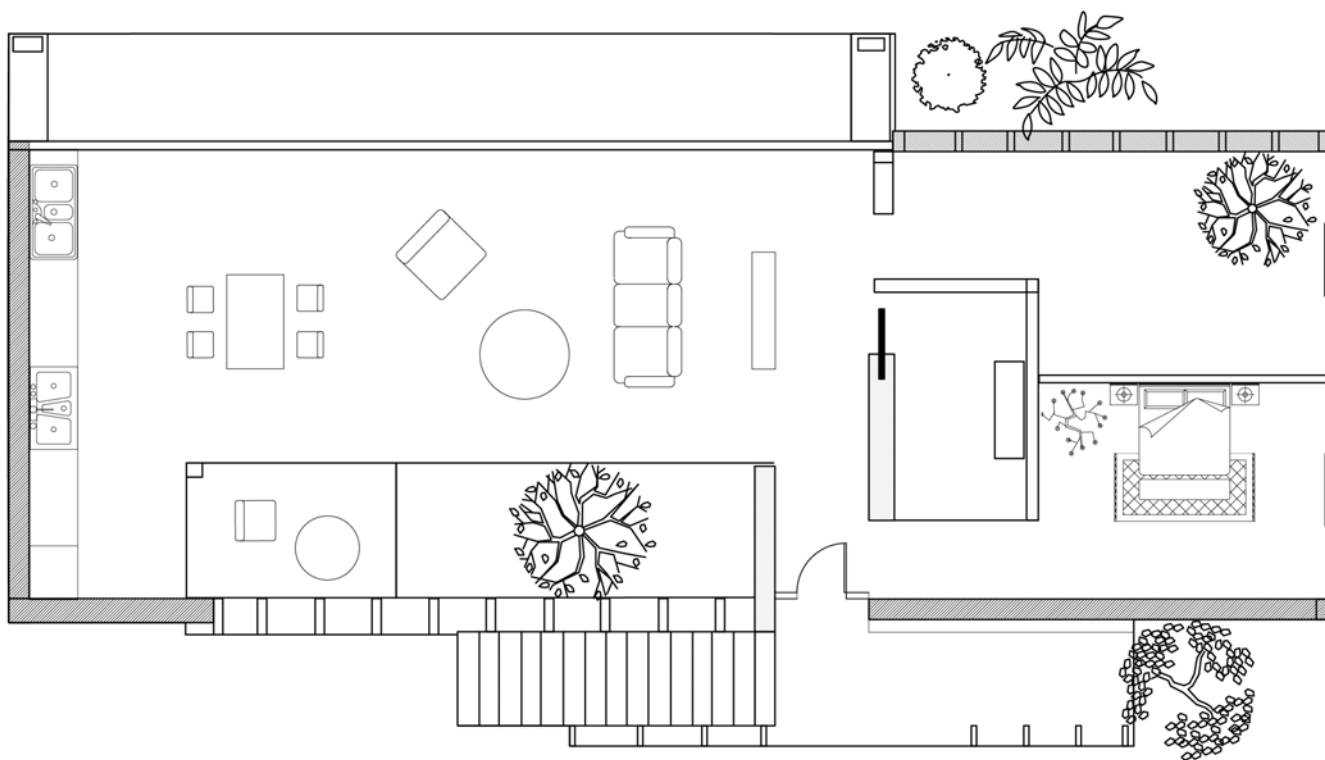

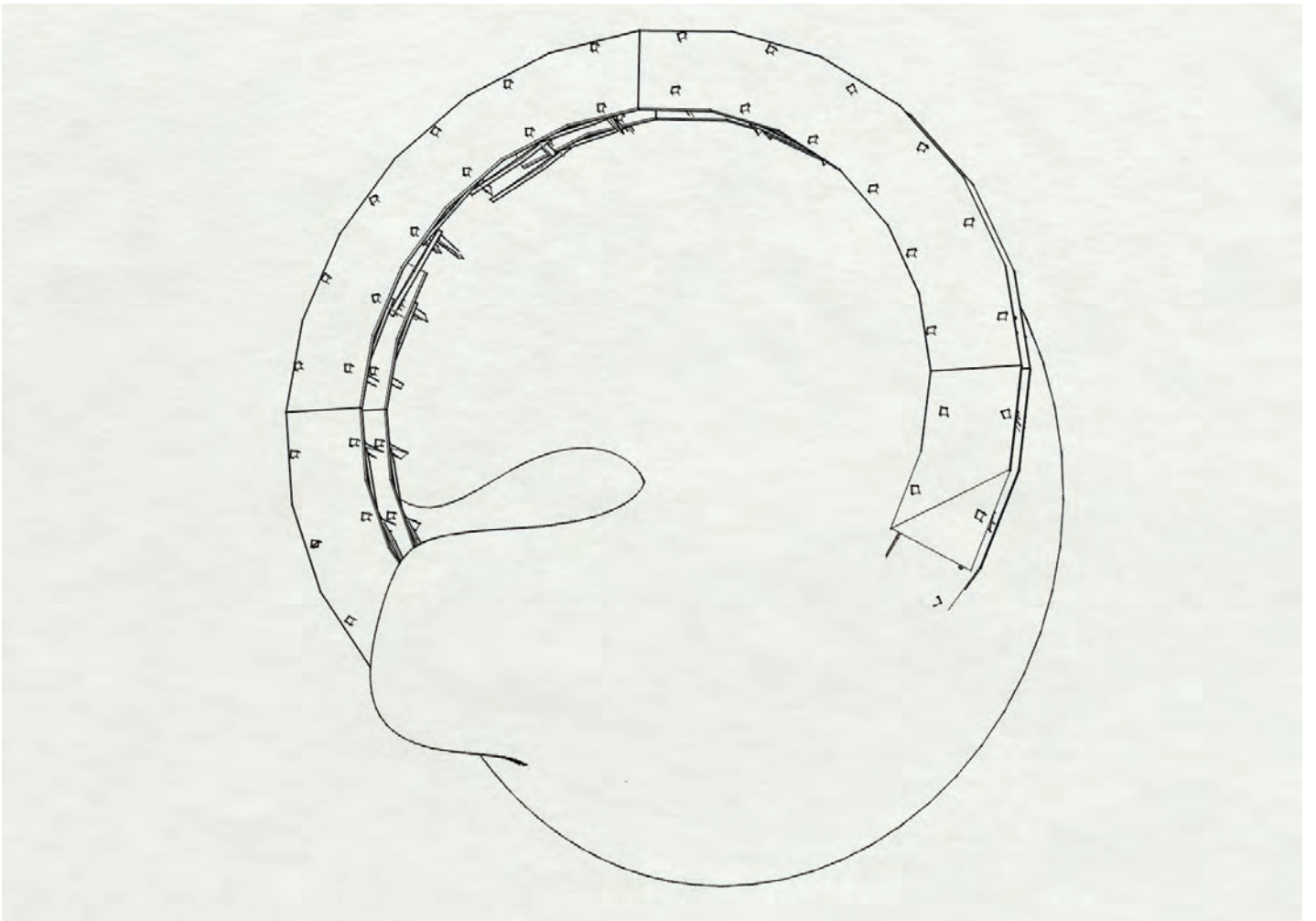
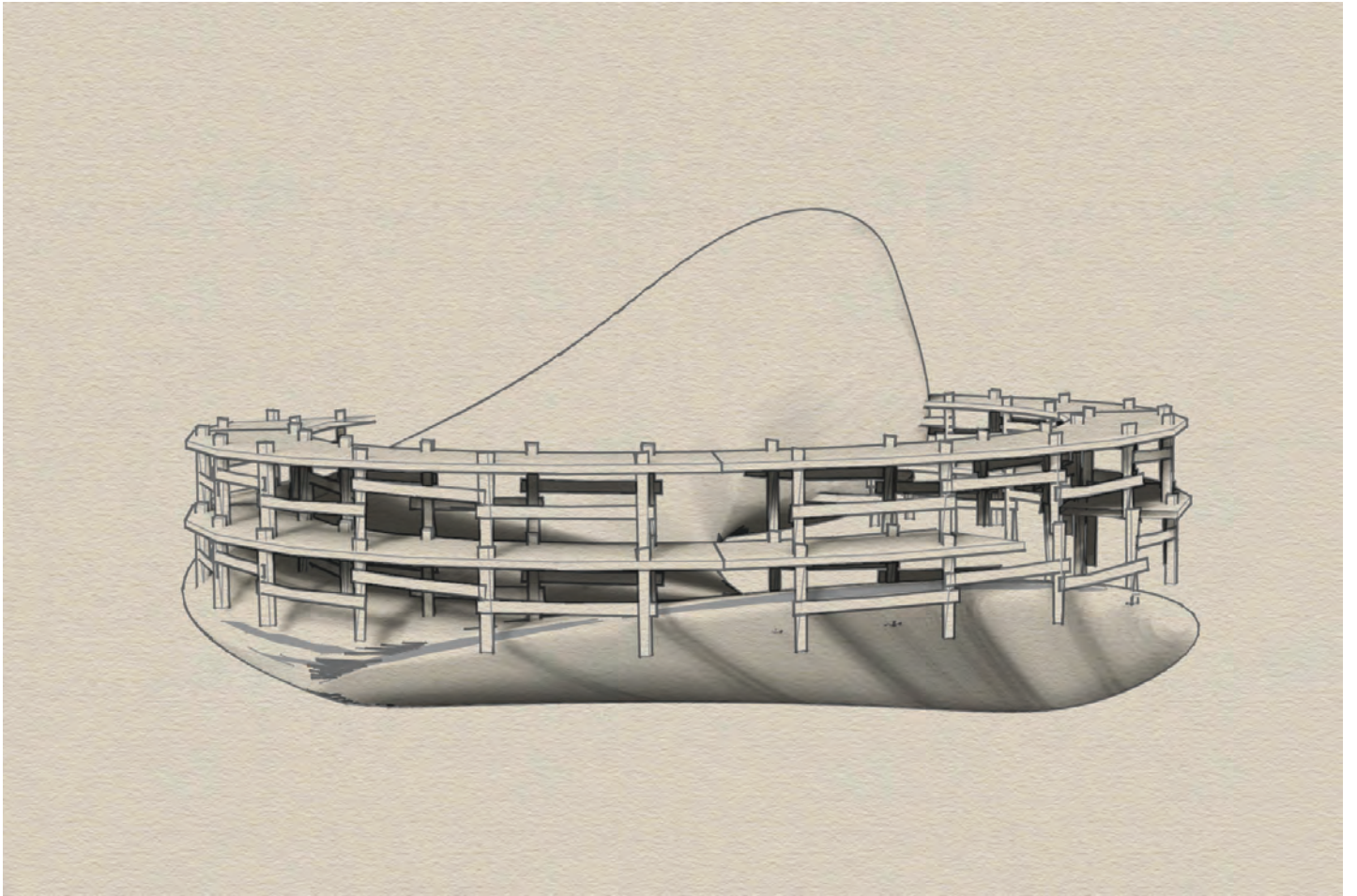

“

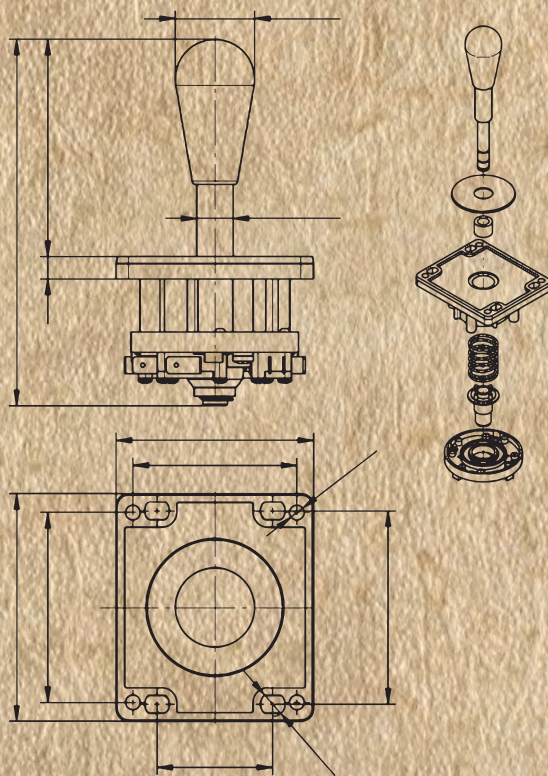

obsolete cd player

cutaway



Final renders —————





www.purniadesigns.com

Thanks for looking

purnia_farrukh@hotmail.com
pfarrukh@cpp.edu

graphic design
architectural design



Purnia Farrukh

